

前 言

本标准是对 GB/T 10708.1—1989《往复运动橡胶密封圈结构尺寸系列 第1部分：单向密封橡胶密封圈》进行修订编制而成。

本标准是首次对 GB/T 10708.1—1989 进行修订，修订后的内容主要有以下改变：

对编排格式、符号规定和标记方法进行了修改；

调整了尺寸和公差表的排列顺序，使结构合理，查寻更方便；

将活塞用密封圈和活塞杆用密封圈的标记方法分别作了规定，以避免对规格相同而用途不同的密封圈因难以区分而出现的错误使用；

修改了标准的英文名称。

本标准是 GB/T 10708《往复运动橡胶密封圈结构尺寸系列》的第1部分。

GB/T 10708 包括以下三个部分：

第1部分(即 GB/T 10708.1)：单向密封橡胶密封圈；

第2部分(即 GB/T 10708.2)：双向密封橡胶密封圈；

第3部分(即 GB/T 10708.3)：橡胶防尘密封圈。

本标准自实施之日起，代替 GB/T 10708.1—1989。

本标准的附录 A 是标准的附录。

本标准由中华人民共和国原化学工业部提出。

本标准由全国橡胶与橡胶制品标准化技术委员会密封制品分技术委员会归口。

本标准起草单位：西北橡胶塑料研究设计院、浙江海门橡胶一厂、西安重型机械研究所。

本标准主要起草人：孙莉萍、曹元礼、董成杰、苏 静。

中华人民共和国国家标准

往复运动橡胶密封圈结构尺寸系列
第 1 部分：单向密封橡胶密封圈

GB/T 10708.1—2000

代替 GB/T 10708.1—1989

Reciprocating rubber seals—Types, dimensions and tolerances—
Part 1: Rubber seals on one-way

1 范围

本标准规定了往复运动用单向密封橡胶密封圈及其压环和支撑环的结构型式、尺寸和公差。
本标准适用于安装在液压缸活塞和活塞杆上起单向密封作用的橡胶密封圈。

2 引用标准

下列标准所包含的条文,通过在本标准中引用而构成为本标准的条文。本标准出版时,所示版本均为有效。所有标准都会被修订,使用本标准的各方应探讨使用下列标准最新版本的可能性。

GB/T 2879—1986 液压缸活塞和活塞杆 动密封沟槽型式、尺寸和公差(neq ISO 5597:1981)

3 符号

- Y——Y形橡胶密封圈(以下简称为Y形圈);
- L——蕾形橡胶密封圈(以下简称为蕾形圈);
- V——V形橡胶密封圈(以下简称为V形圈);
- D ——密封沟槽外径(或缸内径);
- d ——密封沟槽内径(或活塞杆直径);
- f ——间隙;
- L_1 ——短型密封沟槽轴向长度;
- L_2 ——中型密封沟槽轴向长度;
- L_3 ——长型密封沟槽轴向长度;
- D_1 ——密封圈唇部外径;
- D_2 ——密封圈根部外径;
- D_3 ——弹性圈外径;
- S_1 ——密封圈唇部径向截面宽度;
- S_2 ——密封圈根部径向截面宽度;
- S_3 ——弹性圈径向截面宽度;
- d_1 ——密封圈唇部内径;
- d_2 ——密封圈根部内径;
- h ——密封圈高度;
- h_1 ——V形圈唇部高度;
- h_2 ——压环高度;

h_3 ——弹性圈高度；
 h_4 ——支撑环高度。

4 要求

4.1 L_1 密封沟槽用 Y 形圈

4.1.1 活塞 L_1 密封沟槽的密封结构型式及 Y 形圈见图 1, 尺寸和公差见表 1。



图 1 活塞 L_1 密封沟槽的密封结构型式及 Y 形圈

4.1.2 活塞杆 L_1 密封沟槽的密封结构型式及 Y 形圈见图 2, 尺寸和公差见表 2。

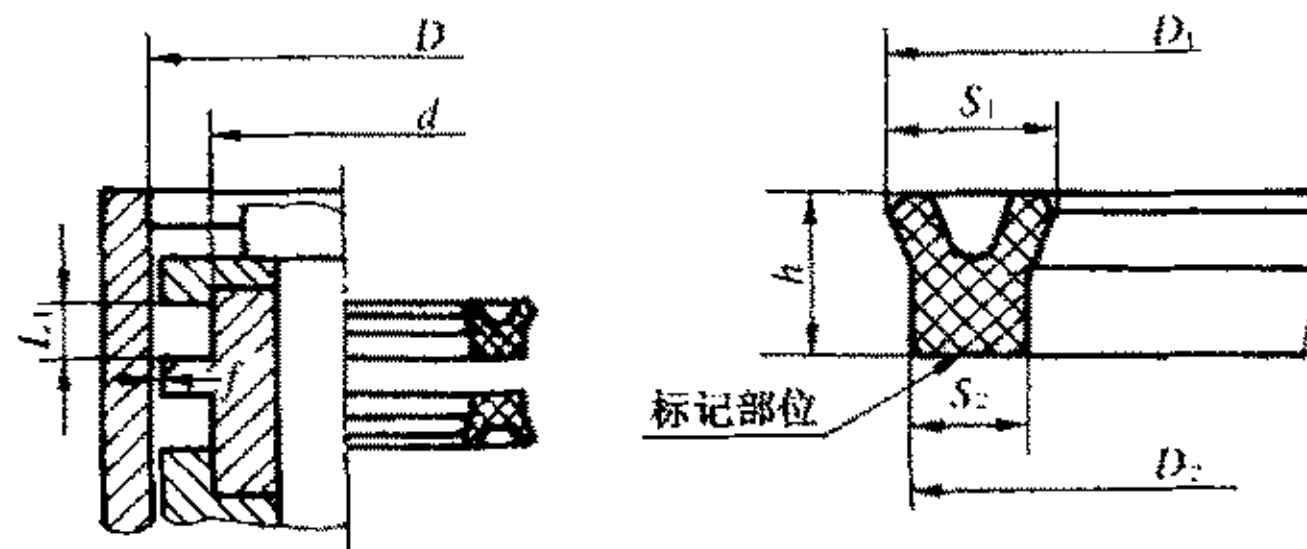

图 2 活塞杆 L_1 密封沟槽的密封结构型式及 Y 形圈

4.2 L_2 密封沟槽用 Y 形圈、蕾形圈

4.2.1 活塞 L_2 密封沟槽的密封结构型式及 Y 形圈、蕾形圈见图 3, 尺寸和公差见表 3。

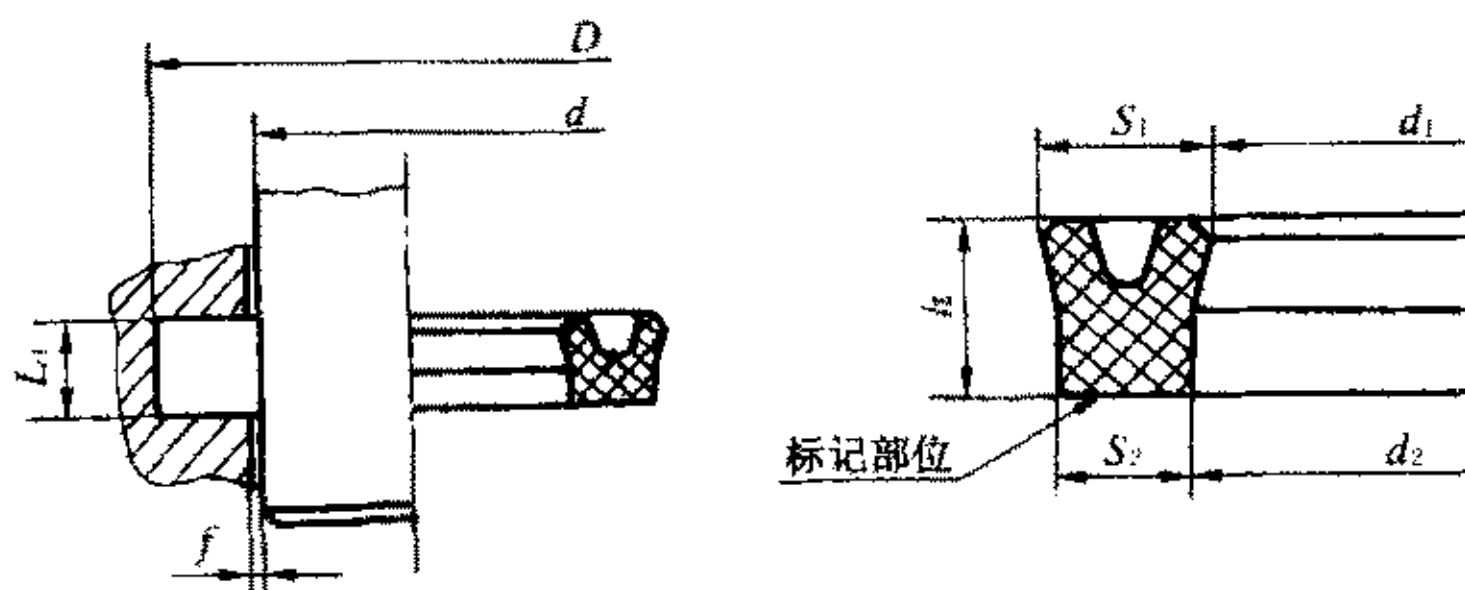

图 3 活塞 L_2 密封沟槽的密封结构型式及 Y 形圈、蕾形圈

表1 活塞 L_1 密封沟槽用 Y 形圈尺寸和公差

mm

D	d	L_1	外 径			宽 度			高 度	
			D_1	D_2	极限偏差	S_1	S_2	极限偏差	h	极限偏差
12	4	5	13	11.5	±0.20	5	3.5	±0.15	4.4	±0.20
16	8		17	15.5						
20	12		21.1	19.4	±0.25					
25	17		26.1	24.4						
32	24		33.1	31.4						
40	32		41.1	39.4						
20	10	6.3	21.2	19.4	6.2	4.4	±0.15	5.6	±0.20	
25	15		26.2	24.4						
32	22		33.2	31.4						
40	30		41.2	39.4						
50	40		51.2	49.4						
56	46		57.5	55.4						
63	53	64.2	62.4	±0.35	9	6.7	8.5	±0.20		
50	35	51.5	49.2							
56	41	57.5	55.2							
63	48	64.5	62.2							
70	65	71.5	69.2							
80	65	81.5	79.2							
90	75	91.5	89.2	±0.45	11.8	9	11.3	±0.20		
100	85	101.5	99.2							
110	95	111.5	109.2							
70	50	71.8	69							
80	60	81.8	79							
90	70	91.8	89							
100	80	101.8	99	±0.60	14.7	11.3	14.8	±0.20		
110	90	111.8	109							
125	105	126.8	124							
140	120	141.8	139							
160	140	161.8	159							
180	160	181.8	179							
125	100	16	127.2	123.8	±0.45	17.8	13.5	18.5	±0.25	
140	115		142.2	138.8						
160	135		162.2	158.8						
180	155		182.2	178.8						
200	175		202.2	198.8						
220	195		222.2	218.8						
250	225	252.2	248.8	±0.90	23.3	18	23	±0.25		
200	170	202.8	198.5							
220	190	222.8	218.5							
250	220	252.8	248.5							
280	250	282.8	278.5							
320	290	322.8	318.5							
360	330	25	362.8	358.5	±1.40	23.3	18	23	±0.25	
400	360		403.5	398						
450	410		453.5	448						
500	460		503.5	498						

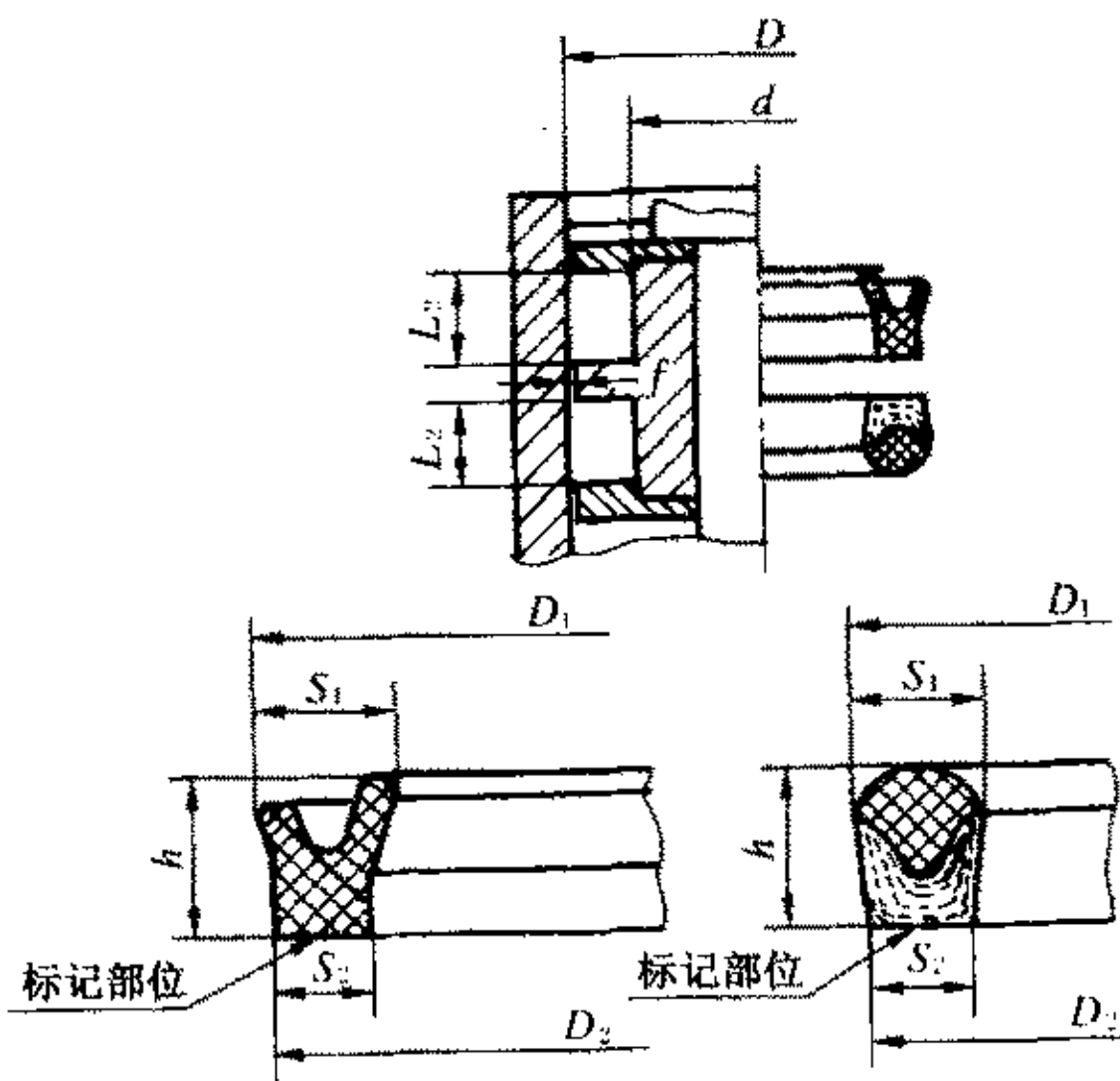
表 2 活塞杆 L_1 密封沟槽用 Y 形圈尺寸和公差

mm

d	D	L_1	内 径			宽 度			高 度	
			d_1	d_2	极限偏差	S_1	S_2	极限偏差	h	极限偏差
6	11	5	5	6.5	± 0.20	5	3.5	± 0.15	4.6	± 0.20
8	16		7	8.5						
10	18		9	10.5						
12	20		11	12.5						
14	22		13	14.5						
16	24		15	16.5						
18	26		17	18.5						
20	28		19	20.5						
22	30		21	22.5						
25	33		24	25.5						
28	38	6.3	26.8	28.6	± 0.25	6.2	4.4	± 0.15	5.6	± 0.20
32	42		30.8	32.6						
36	46		31.8	36.6						
40	50		38.8	40.6						
45	55		43.8	45.6						
50	60	48.8	50.6							
56	71	9.5	54.5	56.8	± 0.35	9	6.7	± 0.15	8.5	± 0.20
63	78		61.5	63.8						
70	85		68.5	70.8						
80	95		78.5	80.8						
90	105		88.5	90.8						
100	120	12.5	98.2	101	± 0.45	11.8	9	± 0.15	11.3	± 0.20
110	130		108.2	111						
125	145		123.2	126						
140	160		138.2	141						
160	185	16	157.8	161.2	± 0.60	14.7	11.3	± 0.15	14.8	± 0.20
180	205		177.8	181.2						
200	225		197.8	201.2						
220	250	20	217.2	221.5	± 0.60	17.8	13.5	± 0.15	18.5	± 0.20
250	280		247.2	251.5						
280	310		277.2	281.5						
320	360	25	316.7	322	± 0.90	23.3	18	± 0.20	23	± 0.25
360	400		356.7	362						

表3 活塞 L₂ 密封沟槽用 Y 形圈、蕾形圈尺寸和公差

mm

D	d	L ₂	Y 形圈						蕾形圈									
			外径			宽度		高度	外径			宽度		高度				
			D ₁	D ₂	极限偏差	S ₁	S ₂	极限偏差	h	极限偏差	D ₁	D ₂	极限偏差	S ₁	S ₂	极限偏差	h	极限偏差
12	4	6.3	13	11.5	±0.20	5	3.5	5.8	5.8	±0.15	±0.20	12.7	11.5	±0.18	4.7	3.5	5.6	5.6
16	8		17	15.5								16.7	15.5					
20	12		21	19.5								20.7	19.5					
25	17		26	24.5	25.7							24.5						
32	24		33	31.5	32.7							31.5						
40	32		41	39.5	40.7							39.5						
20	10	8	21.2	19.4	±0.25	6.2	4.4	7.3	7.3	±0.15	±0.20	20.8	19.4	±0.22	5.8	4.4	7	7
25	15		26.2	24.4								25.8	24.4					
32	22		33.2	31.4								32.8	31.4					
16	30		41.2	39.4								40.8	39.4					
50	40		51.2	49.4								50.8	49.4					
56	46		57.2	55.4								56.8	55.4					
63	53		61.2	62.4								63.8	62.4					
50	35		51.5	49.2								51	49.1					
56	41		57.5	55.2								57	55.1					
63	48		64.5	62.2								64	62.1					
70	55	12.5	71.5	69.2	±0.35	9	6.7	11.5	11.5	±0.15	±0.20	71	69.1	±0.28	8.5	6.6	11.3	±0.20
80	65		81.5	79.2								81	79.1					
90	75		91.5	89.2								91	89.1					
100	85		101.5	99.2								101	99.1					
110	95		111.5	109.2								111	109.1					
70	50	16	71.8	69	±0.35	11.8	9	15	15	±0.15	±0.20	71.2	68.6	±0.28	11.2	8.6	14.5	14.5
80	60		81.8	79								81.2	78.6					
90	70		91.8	89								91.2	88.6					
100	80		101.8	99								101.2	98.6					
110	90		111.8	109								111.2	108.6					
125	105		126.8	124								126.2	123.6					
140	120		141.8	139								141.2	138.6					
160	140		161.8	159								161.2	158.6					
180	160		181.8	179								181.2	178.6					
125	100		20	127.2								123.8	±0.45					
140	115	142.2		138.8	141.3	138.2												
160	135	162.2		158.8	161.3	158.2												
180	155	182.2		178.8	181.3	178.2												
200	175	202.2		198.8	201.3	198.2												
220	195	222.2		218.8	221.3	218.2												
250	225	252.2	248.8	251.3	248.2													
200	170	25	202.8	198.5	±0.60	17.8	13.5	23	23	±0.20	±0.25	201.4	198	±0.45	16.4	12.7	22.5	22.5
220	190		222.8	218.5								221.4	218					
250	220		252.8	248.5								251.4	248					
280	250		282.8	278.5								281.4	278					
320	290		322.8	318.5								321.4	318					
360	330		362.8	358.5								361.4	358					
400	360	32	403.3	398	±0.90	23.3	18	29	29	±0.20	±0.25	401.8	397	±0.60	21.8	17	28.5	±0.25
450	410		453.3	448								451.8	447					
500	460		503.3	498								501.8	497					

4.2.2 活塞杆 L_2 密封沟槽的密封结构型式及 Y 形圈、蕾形圈见图 4, 尺寸和公差见表 4。



图 4 活塞杆 L_2 密封沟槽的密封结构型式及 Y 形圈、蕾形圈

4.3 L_3 密封沟槽用 V 形组合密封圈

4.3.1 活塞 L_3 密封沟槽用 V 形组合密封圈由 V 形圈、压环和弹性圈组合而成, 密封结构型式及 V 形圈、压环和弹性圈见图 5, 尺寸和公差见表 5。

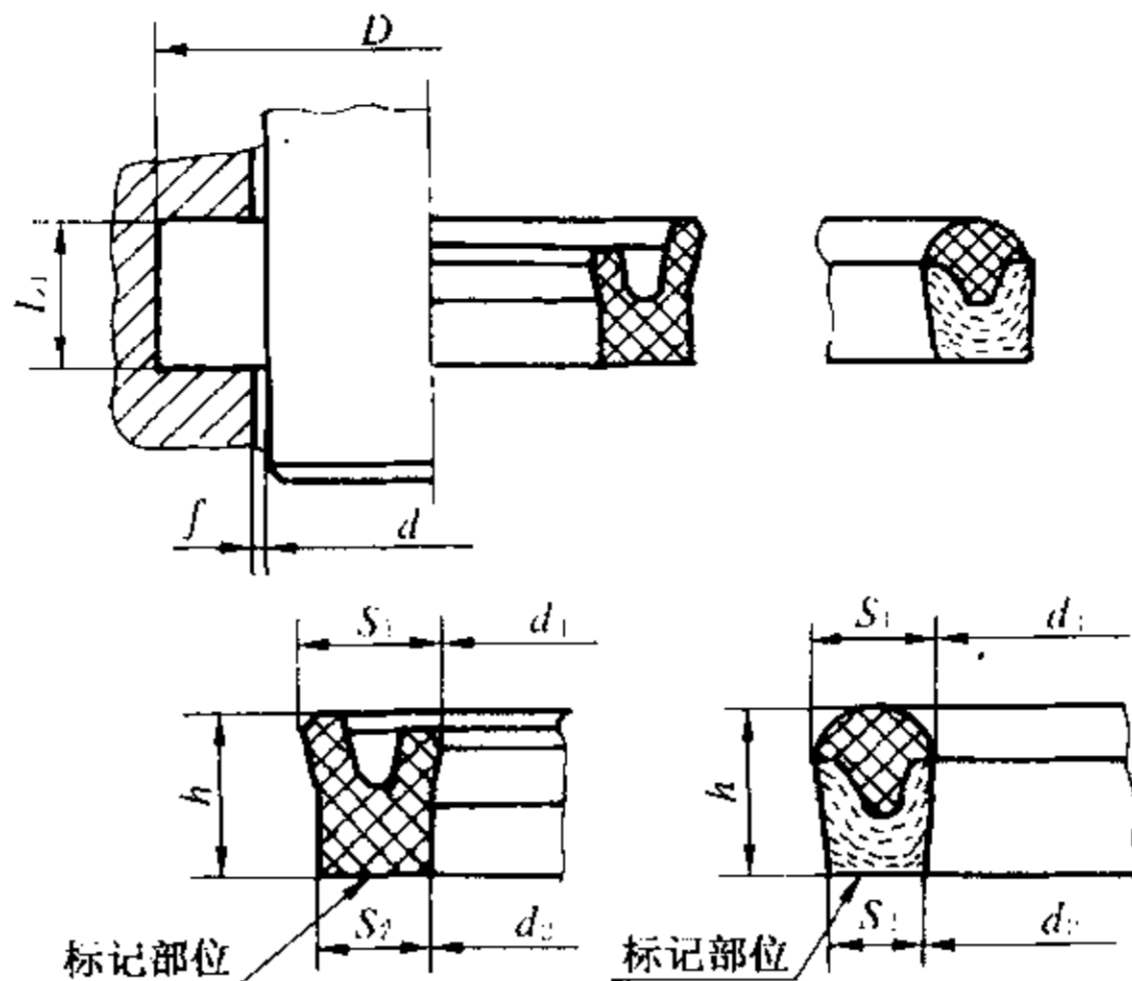

图 5 活塞 L_3 密封沟槽的密封结构型式及 V 形圈、压环和弹性圈

4.3.2 活塞杆 L_3 密封沟槽用 V 形组合密封圈, 由 V 形圈、压环和塑料支撑环组成, 密封结构型式及 V 形圈、压环、支撑环见图 6, 尺寸和公差见表 6。

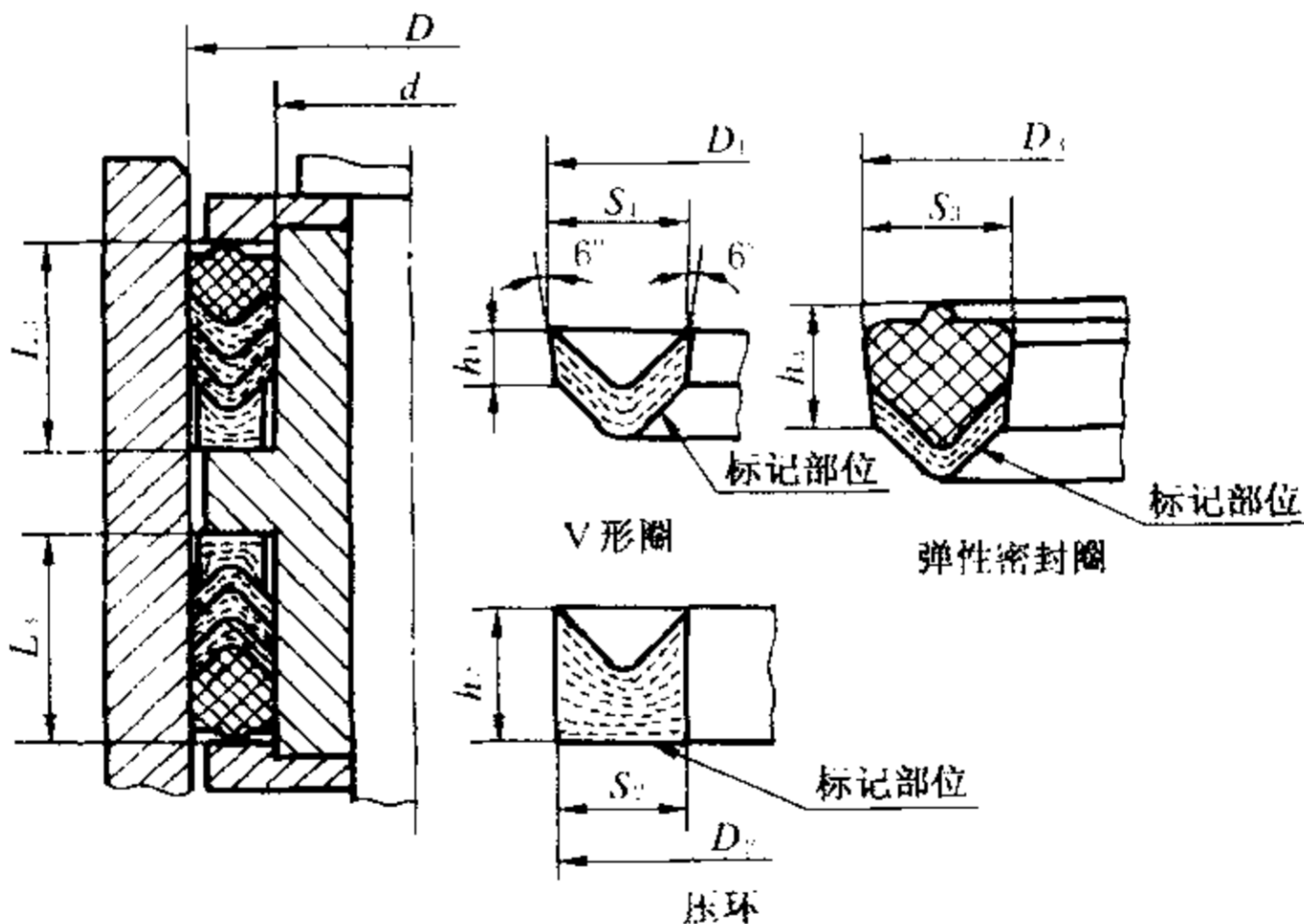

图 6 活塞杆 L_3 密封沟槽的密封结构型式及 V 形圈、压环和支撑环

表 4 活塞杆 L_2 密封沟槽用 Y 形圈、蕾形圈尺寸和公差

mm

d	D	L_2	Y 形圈						蕾形圈																
			内 径			宽 度		高 度	内 径			宽 度		高 度											
			d_1	d_2	极限 偏差	S_1	S_2	极限 偏差	h	极限 偏差	d_1	d_2	极限 偏差	S_1	S_2	极限 偏差	h	极限 偏差							
6	14	6.3	5	6.5	±0.20		3.5	5.8		5.3	6.5	±0.18	4.7	3.5		5.5									
8	16		7	8.5						7.3	8.5														
10	18		9	10.5						9.3	10.5														
12	20		11	12.5						11.3	12.5														
14	22		13	14.5						13.3	14.5														
16	24		15	16.5						15.3	16.5														
18	26		17	18.5						17.3	18.5														
20	28		19	20.5						19.3	20.5														
22	30		21	22.5						21.3	22.5														
25	33		24	25.5						24.3	25.5														
10	20	8	8.8	10.6	±0.20		4.4	7.3		9.2	10.6	±0.18	5.8	4.4		7									
12	22		10.8	12.6						11.2	12.6														
14	24		12.8	14.6						13.2	14.6														
16	26		14.8	16.6						15.2	16.6														
18	28		16.8	18.6						17.2	18.6														
20	30		18.8	20.6						19.2	20.6														
22	32		20.8	22.6						21.2	22.6														
25	35		23.8	25.6						24.2	25.6														
28	38		26.8	28.6						27.2	28.6														
32	42		30.8	32.6						31.2	32.6														
36	46	34.8	36.6	35.2	36.6																				
10	50	12.5	38.8	40.6	±0.25		6.7	11.5		39.2	40.6	±0.22	8.5	6.6		11.3									
15	55		43.8	45.6						44.2	45.6														
50	60		48.8	50.6						49.2	50.6														
28	13		26.5	28.8						27	28.9							±0.15	±0.20	31	32.9	±0.15			±0.20
32	17		30.5	32.8						31	32.9														
36	21		34.5	36.8						35	36.9														
40	25		38.5	40.8						39	40.9														
45	30		43.5	45.8						44	45.9														
50	35		48.5	50.8						49	50.9														
56	41		54.5	56.8						55	56.9														
63	47	61.5	63.8	62	63.9																				
70	53	68.5	70.8	69	70.9																				
80	61	78.5	80.8	79	80.9																				
90	71	88.5	90.8	89	90.9																				
56	76	16	54.2	57	±0.25		9	15		54.8	57.4	±0.22	11.2	8.6		14.5									
63	83		61.2	64						61.8	64.4														
70	90		68.2	71						68.8	71.4														
80	100		78.2	81						78.8	81.4														
90	110		88.2	91						88.8	91.4														
100	120		98.2	101						98.8	101.4														
110	130		108.2	111						108.8	111.4														
125	145		123.2	126						123.8	126.4														
140	160		138.2	141						138.8	141.4														
100	125		97.8	101.2						98.7	101.8							±0.35		18.5		±0.35	13.8	10.7	
110	135	107.8	111.2	108.7	111.8																				
125	150	122.8	126.2	123.7	126.8																				
140	165	137.8	141.2	138.7	141.8																				
160	185	157.8	161.2	158.7	161.8																				
180	205	177.8	181.2	178.7	181.8																				
200	225	197.8	201.2	198.7	201.8																				
160	190	157.2	161.5	158.6	162	±0.45		23		±0.45	16.4	13		22.5											
180	210	177.2	181.5	178.6	182																				
200	230	197.2	201.5	198.6	202																				
220	250	217.2	221.5	218.6	222																				
250	280	247.2	251.5	248.6	252																				
280	310	277.2	281.5	278.6	282																				
320	360	317.7	322	318.2	323											±0.60		29		±0.60	21.8	17		28.5	
360	400	357.7	362	358.2	363																				

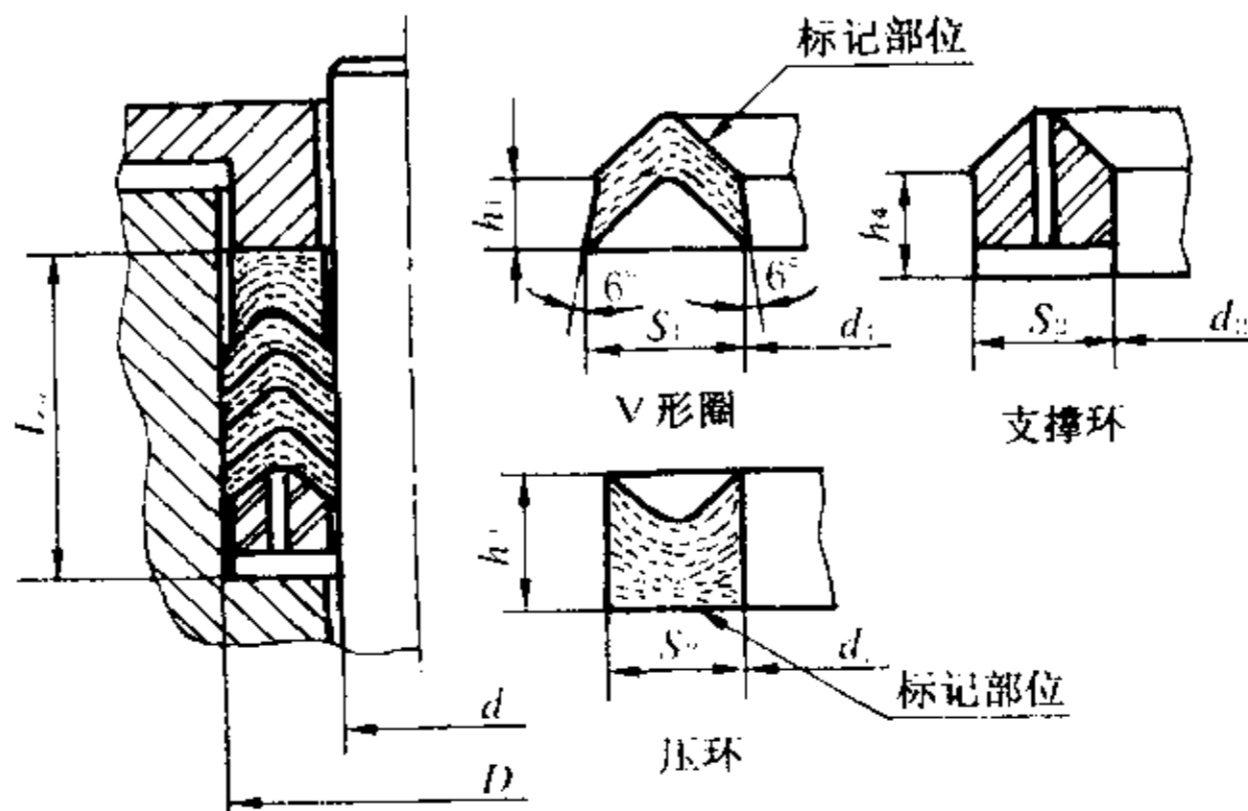
表 5 活塞 L_3 密封沟槽用 V 形圈、压环和弹性圈尺寸和公差

mm

D	d	L_3	外 径				宽 度				高 度				V 形圈 数量
			D_1	D_2	D_3	极限 偏差	S_1	S_2	S_3	极限 偏差	h_1	h_2	h_3	极限 偏差	
20	10	16	20.6	19.7	20.8	± 0.22	5.6	4.7	5.8		3	6	6.5		1
25	15		25.6	24.7	25.8										
32	22		32.6	31.7	32.8										
40	30		40.6	39.7	40.8										
50	40		50.6	49.7	50.8										
56	46		56.6	55.7	56.8										
63	53		63.6	62.7	63.8										
50	35	25	50.7	49.5	51.1	± 0.28	8.2	7	8.6		4.5	7.5	8		2
56	41		56.7	55.5	57.1										
63	48		63.7	62.5	64.1										
70	55		70.7	69.5	71.1										
80	65		80.7	79.5	81.1										
90	75		90.7	89.5	91.1										
100	85		100.7	99.5	101.1										
110	95	110.7	109.5	111.1											
70	50	32	70.8	69.4	71.3	± 0.35	10.8	9.4	11.3	± 0.15	5	10	11	± 0.20	2
80	60		80.8	79.1	81.3										
90	70		90.8	89.4	91.3										
100	80		100.8	99.4	101.3										
110	90		110.8	109.4	111.3										
125	105		125.8	124.4	126.3										
140	120		140.8	139.4	141.3										
160	140	160.8	159.4	161.3											
180	160	180.8	179.4	181.3											
125	100	40	126	124.4	126.6	± 0.45	13.5	11.9	14.1		6	12	15		3
140	115		141	139.4	141.6										
160	135		161	169.4	161.6										
180	155		181	179.4	181.6										
200	175		201	199.4	201.6										
220	195		221	219.4	221.6										
250	225		251	249.4	251.6										
200	170	50	201.3	199.2	201.9	± 0.60	16.3	14.2	16.8		6.5	17.5		3	
220	190		221.3	219.2	221.9										
250	220		251.3	249.2	251.9										
280	250		281.3	279.2	281.9										
320	290		321.3	319.2	321.9										
360	330		361.3	359.2	361.9										
400	360		401.6	399	402.1										
450	410	63	451.6	449	452.1	± 0.90	21.6	19	22.1	± 0.20	7	14	26.5	± 0.25	
500	400		501.6	499	502.1										

表 6 活塞杆 L_3 密封沟槽用 V 形圈、压环和支撑环尺寸和公差

mm

d	D	L_3	内 径			宽 度			高 度			V 形圈 数量
			d_1	d_2	极限 偏差	S_1	S_2	极限 偏差	h_1	h_2	h_3	
6	14	14.5	5.5	6.3	±0.18	4.5	3.7	±0.15	2.5	6	±0.20	2
8	16											
10	18											
12	20											
14	22											
16	24											
18	26											
20	28											
22	30											
25	33											
10	20	16	9.4	10.3	±0.22	5.6	4.7	±0.15	3	6.5	±0.20	2
12	22											
14	24											
16	26											
18	28											
20	30											
22	32											
25	35											
28	38											
32	42											
36	46											
40	50											
45	55											
50	60											
28	43	25	27.3	28.5	±0.28	8.2	7	±0.15	4.5	8	±0.20	3
32	47											
36	51											
40	55											
45	60											
50	65											
56	71											
63	78											
70	85											
80	95											
90	105											
56	76	32	55.2	56.6	±0.22	10.8	9.4	±0.15	6	10	±0.20	3
63	83											
70	90											
80	100											
90	110											
100	120											
110	130											
125	145											
140	160											
100	125	40	99	100.6	±0.35	13.5	11.9	±0.15	12	±0.20	4	
110	135											
125	150											
140	165											
160	185											
180	205											
200	225											
160	190	50	158.8	160.8	±0.35	16.2	14.2	±0.20	6.5	14	±0.25	5
180	210											
200	230											
220	250											
250	280											
280	310											
320	360	63	318.4	321	±0.60	21.6	19	±0.25	7	15.5	±0.25	6
360	400											

5 标记

5.1 活塞用密封圈的标记方法以“密封圈代号、 $D \times d \times L_1(L_2, L_3)$ 、制造厂代号”表示。

示例：密封沟槽外径(D)为 80 mm，密封沟槽内径(d)为 65 mm，密封沟槽轴向长度(L_1)为 9.5 mm 的活塞用 Y 形圈，标记为：

Y80×65×9.5 ××

5.2 活塞杆用密封圈的标记方法以“密封圈代号、 $d \times D \times L_1(L_2, L_3)$ 、制造厂代号”表示。

示例：密封沟槽内径(d)为 70 mm，密封沟槽外径(D)为 85 mm，密封沟槽轴向长度(L_1)为 9.5 mm 的活塞杆用 Y 形圈，标记为：

Y70×85×9.5 ××

附录 A

(标准的附录)

单向密封橡胶密封圈使用条件

单向密封橡胶密封圈使用条件见表 A1。

表 A1 单向密封橡胶密封圈使用条件

密封圈结构型式	往复运动速度 m·s	间隙 f mm	工作压力范围 MPa
Y 形橡胶密封圈	0.5	0.2	0~15
		0.1	0~20
	0.15	0.2	
		0.1	
蕾形橡胶密封圈	0.5	0.3	0~45
		0.1	
	0.15	0.3	0~30
		0.1	0~50
V 形组合密封圈	0.5	0.3	0~20
		0.1	0~40
	0.15	0.3	0~25
		0.1	0~60